

folding stairs

7.21 series

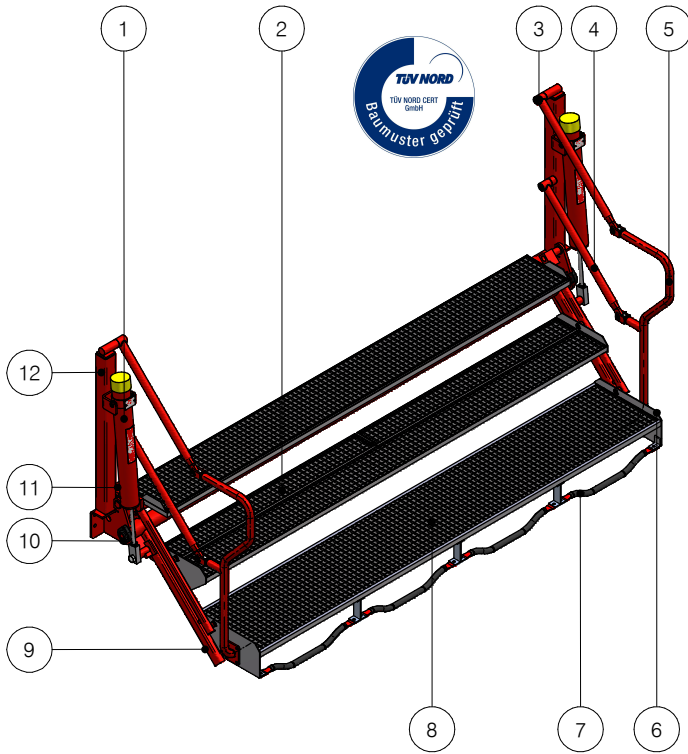

STANDARD RANGE	OPTIONS
7.21.08 - 2 steps	chain-locking device
7.21.12 - 3 steps	safety cage
7.21.16 - 4 steps	pneum. operation with brakes
pull-up cord	parking position detection
steps galvanised	step width up to 3.500 mm
construction coated/galvanised	add. safety railing equipment
	fully stainless steel execution

No.	NAME
1	spring cylinder for balancing
2	anti jam provisions
3	nylon bearings
4	knee list
5	firm grip
6	kick rim
7	rubber contact bar
8	non-skid steps
9	reinforced mainframe for improved stability
10	bearings
11	foot lock
12	solid support frame (coated or galvanised)

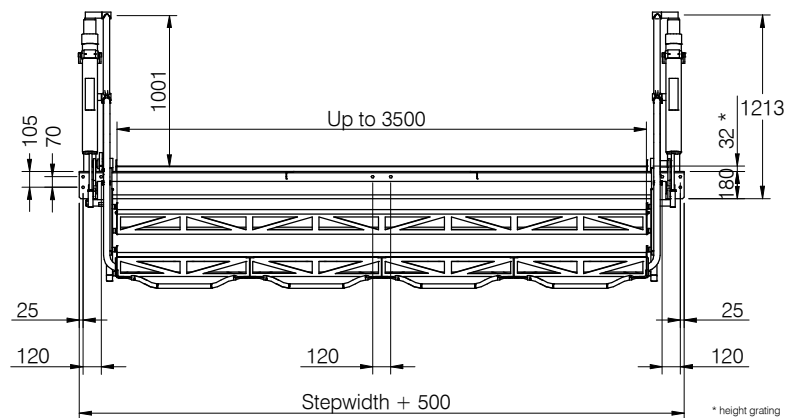
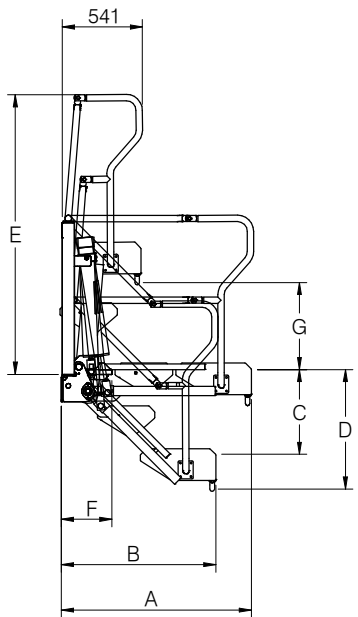

MODEL	STEPS	DIMENSIONS						
		A	B	C	D	E	F	G
		mm	mm	mm	mm	mm	mm	mm
7.21.08	2	850	700	250	500	1450	335	160
7.21.12	3	1250	1000	550	800	1850	335	560
7.21.16	4	1650	1300	850	1100	2250	335	960

subject to technical modifications