

drawbridge

7.21 series

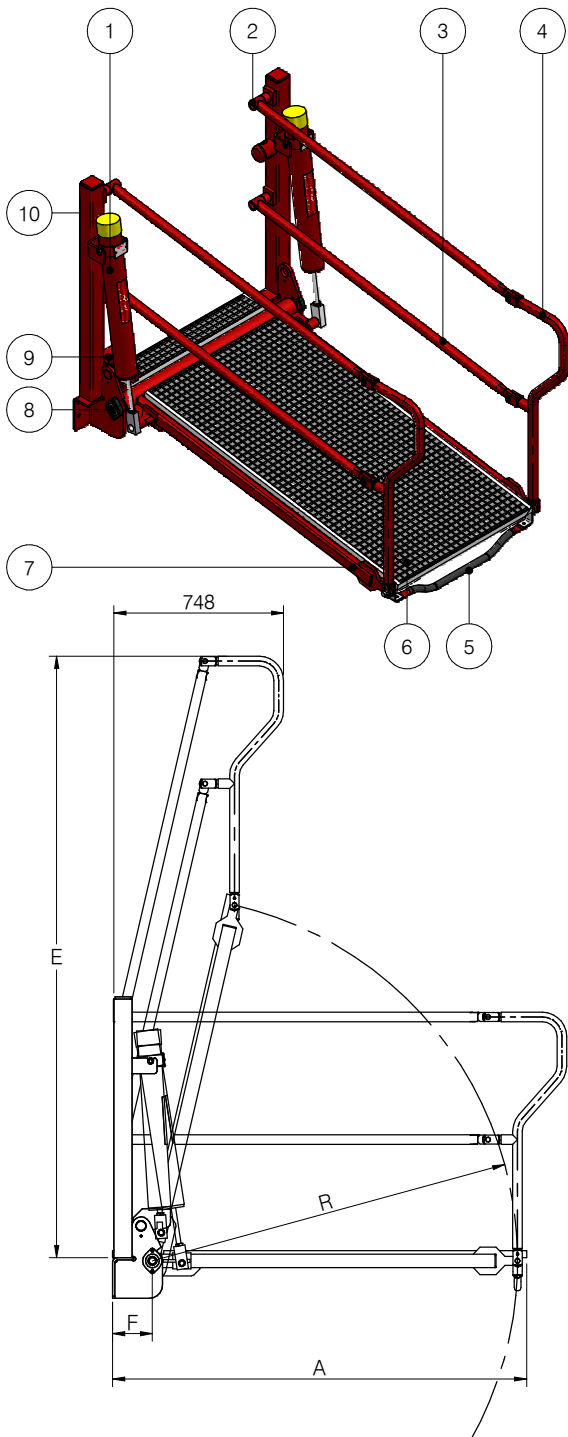

STANDARD RANGE	OPTIONS
grating 800 x 1.200	chain-locking device
grating 800 x 1.600	pneumatical operation
grating 800 x 2.000	parking position detection
grating 800 x 2.400	grating width up to 3.500 mm
other dimensions available	add. safety railing equipment
pull-up cord	fully stainless steel execution
grating galvanised	safety cage std. dimensions;
construction coated/galvanised	1400x1400/2800x1400

No.	NAME
1	spring cylinder for balancing
2	nylon bearings
3	knee list
4	railing
5	rubber contact bar
6	non-skid grating
7	reinforced mainframe for improved stability
8	bearings
9	foot lock
10	solid support frame (coated or galvanised)

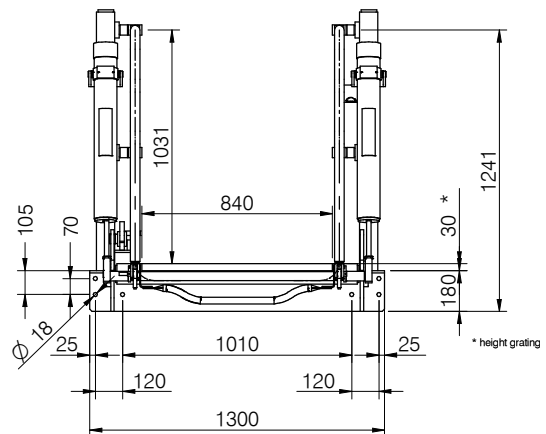

MODEL	DIMENSIONS				LIVE LOAD		MAX. LOAD ON FRONT EDGE OF PLATFORM	
	A	E	F	R	kg	kN	kN	kNm
	mm	mm	mm	mm				
800 x 1.200	1425	2250	175	1210	200	1,96	5,39	2,65
800 x 1.600	1825	2650	175	1610	220	2,16	6,77	4,51
800 x 2.000	2225	3050	175	2010	260	2,55	8,24	6,86
800 x 2.400	2625	3450	175	2410	320	3,14	12,00	15,00

subject to technical modifications