

## pipe hinge

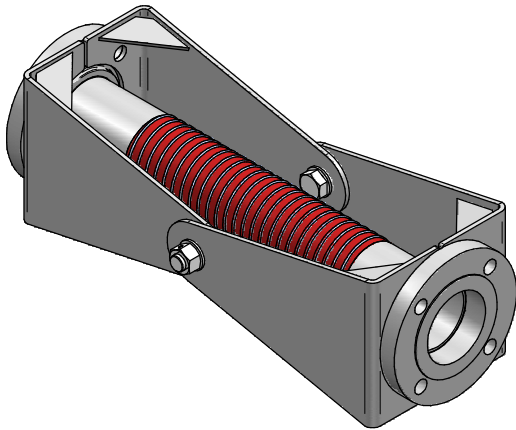

ITEM	SPECIFICATIE
afmetingen	DN80 (3") tot DN150 (6")
materiaal	rvs, staal (gegalvaniseerd)
slang	composite slang met rvs spiraal
eind aansluiting	flens ANSI/DIN

PROCES GEGEVENS	WAARDEN
druk	tot 10 bar
temperatuur	-40°C / +100°C

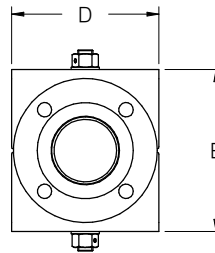
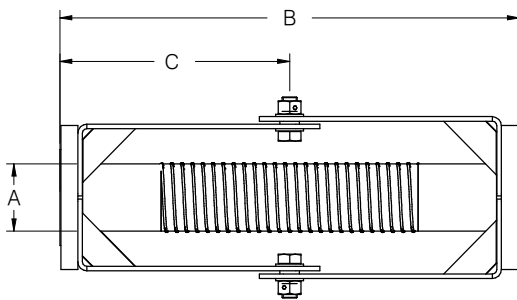

MAAT		AFMETINGEN				GEWICHT kg
A		B	C	D	E	
inch	mm	mm	mm	mm	mm	
3"	88,9	616	308	195	214	34,0
4"	114,3	756	378	235	254	45,4
6"	168,3	940	470	285	304	83,9

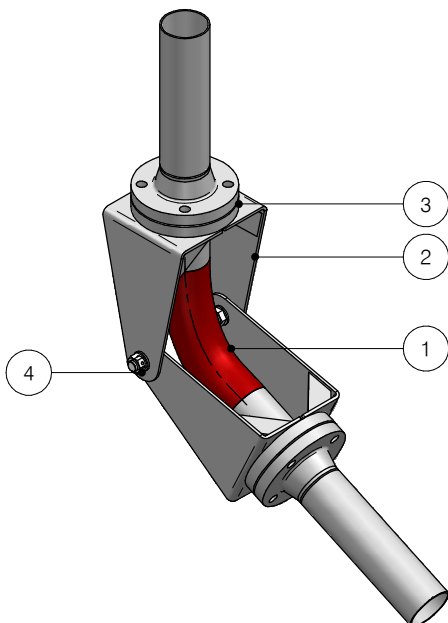

Nr.	NAAM
1	slang
2	zijplaten
3	flens ANSI/DIN
4	rvs scharnier

technische modificaties voorbehouden