

Quick-Connect / Dis-Connect coupling

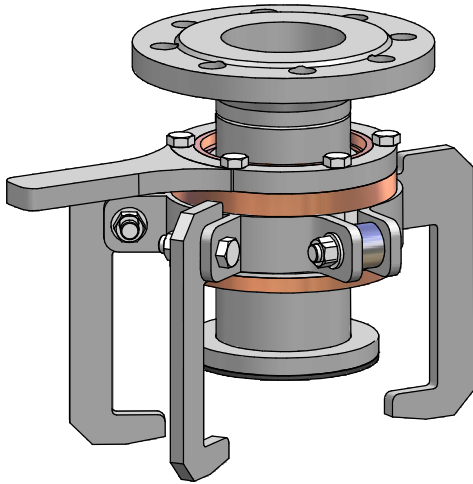

| ITEM | SPECIFICATION |
|--------------|--|
| dimensions | DN50 (2") up to DN150 (6") |
| material | stainless steel, steel, aluminium |
| seals | PTFE, Viton, EPDM |
| operation | manually |
| adaptability | ANSI: WNF, LJF, slip-on (150/300#) DIN: WNF, LJF, flat welding (PN10/16/40) |
| connection | flanged ANSI/DIN |

| PROCESS DATA | VALUES |
|--------------|----------------|
| pressure | up to 10 bar |
| temperature | -40°C / +100°C |

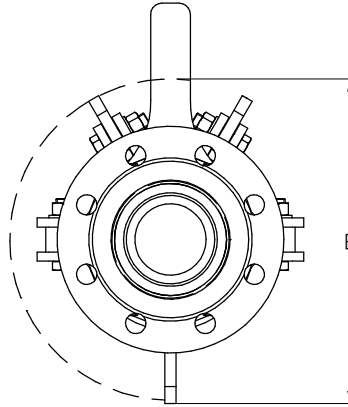
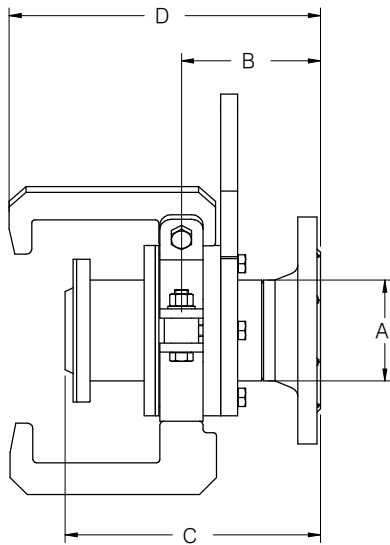

| SIZE | | DIMENSIONS | | | | | | | | WEIGHTS |
|------|------|------------|------|-----|------|-----|------|-----|------|-------------|
| A | | B | | C | | D | | E | | incl. blank |
| mm | inch | mm | inch | mm | inch | mm | inch | mm | inch | kg |
| 50 | 2" | 128 | 5,0 | 200 | 7,9 | 230 | 9,1 | 205 | 8,1 | 20,0 |
| 80 | 3" | 123 | 4,8 | 225 | 8,9 | 275 | 10,8 | 286 | 11,3 | 25,0 |
| 100 | 4" | 130 | 5,1 | 225 | 8,9 | 275 | 10,8 | 380 | 15,0 | 41,7 |
| 150 | 6" | 146 | 5,8 | 239 | 9,4 | 371 | 14,6 | 483 | 19,0 | 75,3 |

subject to technical modifications