

## swivel joint

## type 30-3620 - PFA gelineed

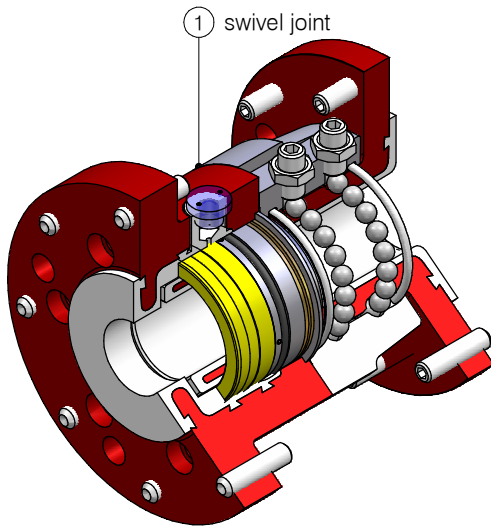

ITEM	SPECIFICATIE
afmetingen	DN50 (2"), DN80 (3"), DN100 (4")
swivel flens	staal 42CrMo4 PFA gelineed
binnenbus	staal 42CrMo4 PFA gelineed
buitenbus	staal 42CrMo4 PFA gelineed
seals	PTFE
eind verbinding	flenzen DIN

PROCES GEGEVENS	WAARDEN
druk	tot 50 bar
temperatuur	-50°C / +200°C

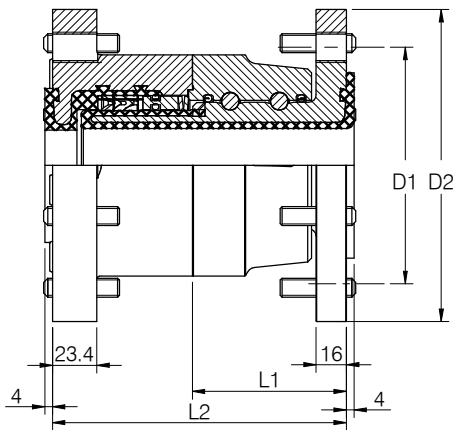

MAAT	AFMETINGEN				GEWICHT			
	D1	D2	L1	L2	swivel joint	midpart		
	mm	inch	mm	mm	mm	mm	kg	kg
50	2"	125	165	81	155	11,5	6,7	
80	3"	160	200	81	155	15,8	9,2	
100	4"	180	220	81	155	18,8	11,5	

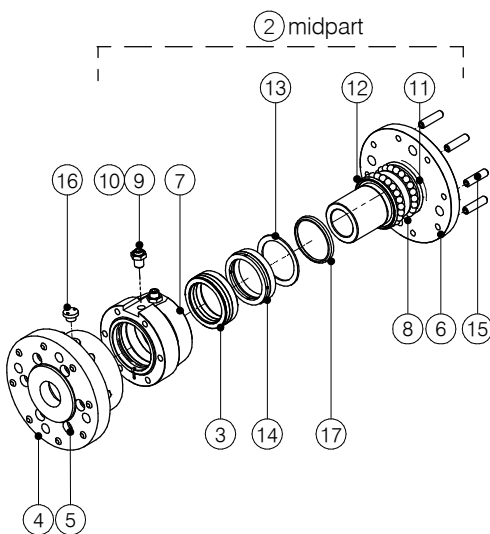

ITEM	NAAM	MATERIAAL	ORDER NO.					
			qty	DN 50	qty	DN 80	qty	DN 100
3	product seal kit	PTFE	1	72925	1	72935	1	72945
4	swivel flens	staal	1	70572	1	70582	1	70592
4	swivel flens	st.staal	1	83612	1	76882	1	83622
5	bouten	staal	6	78165	8	78165	8	78165
6	binnenbus *	staal	1	70632	1	70642	1	70652
6	binnenbus *	st.staal	1	83632	1	76802	1	83642
7	buitenbus *	staal	1	22512	1	22612	1	22702
7	buitenbus *	st.staal	1	52102	1	52112	1	52122
8	kogel	staal	44	43195	64	43195	78	43195
9	kogelplug	staal	2	49675	2	49675	2	49675
10	moer	staal	2	47635	2	47635	2	47635
11	stof seal	PTFE	1	41945	1	41965	1	41985
12	kamer seal	PTFE	1	41945	1	41965	1	41985
13	kopveer	staal	3	49885	2	49895	2	49905
14	druk ring	staal	1	100632	1	100622	1	100292
15	afstandbout	staal	16	78155	16	78155	16	78155
16	kijkvenster		1	82575	1	82575	1	82575
17	klemring	staal	1	100633	1	100623	1	100293

\* alleen leverbaar als onderdeel van gehele swivel excl. flens

technische modificaties voorbehouden