

swivel joint

type 30-0470

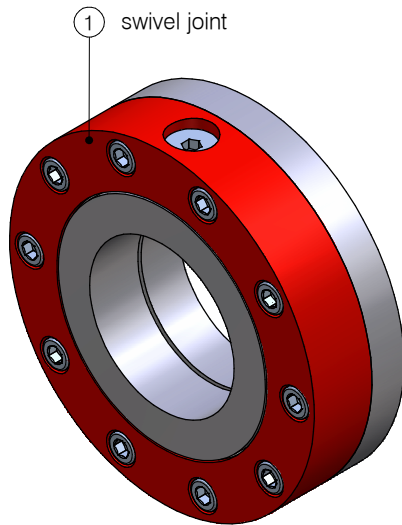

ITEM	SPECIFICATIE
afmetingen	DN80 (3"), DN100 (4")
swivel flens	rvs 1.4571
binnenbus	rvs 1.4571
buitenbus	staal 42CrMo4
seals	PTFE, Viton, EPDM
eind verbinding	laseinden

PROCESGEGEVENS	WAARDEN
druk	tot 50 bar
temperatuur	-50°C / +200°C

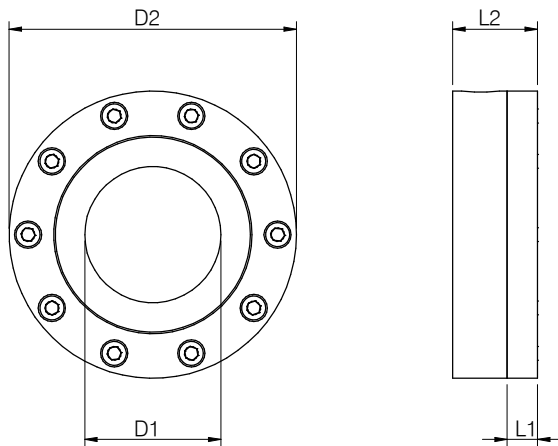

MAAT		AFMETINGEN				GEWICHT	
		D1	D2	L1	L2	swivel joint	mid part
mm	inch	mm	mm	mm	mm	kg	kg
80	3"	90	190	20	56	8	5,5
100	4"	98	280	26	77	27	17

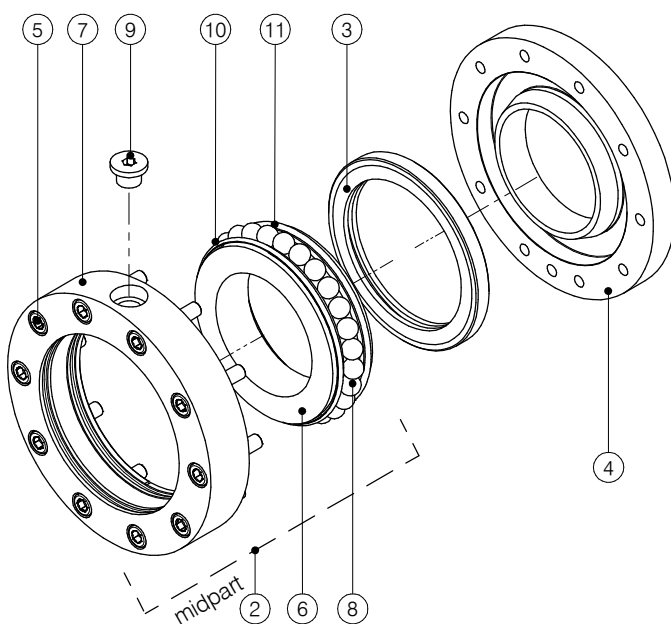

ITEM	NAAM	AANTAL	
		80	100
2	midpart	1	1
3	product seal, PTFE	1	1
3	product seal, Viton	1	1
3	product seal, EPDM	1	1
4	swivel flens	1	1
5	bout	10	12
6	binnenbus *	1	1
7	buitenbus *	1	1
8	kogel	27	38
9	kogelplug	1	1
10	stof seal, PTFE	1	1
10	stof seal, NBR	1	1
10	stof seal, FPM	1	1
11	kamer seal, PTFE	1	1
11	kamer seal, FPM	1	1

* alleen leverbaar als onderdeel van gehele swivel excl. flens

technische modificaties voorbehouden