

hose reel

type TH marine

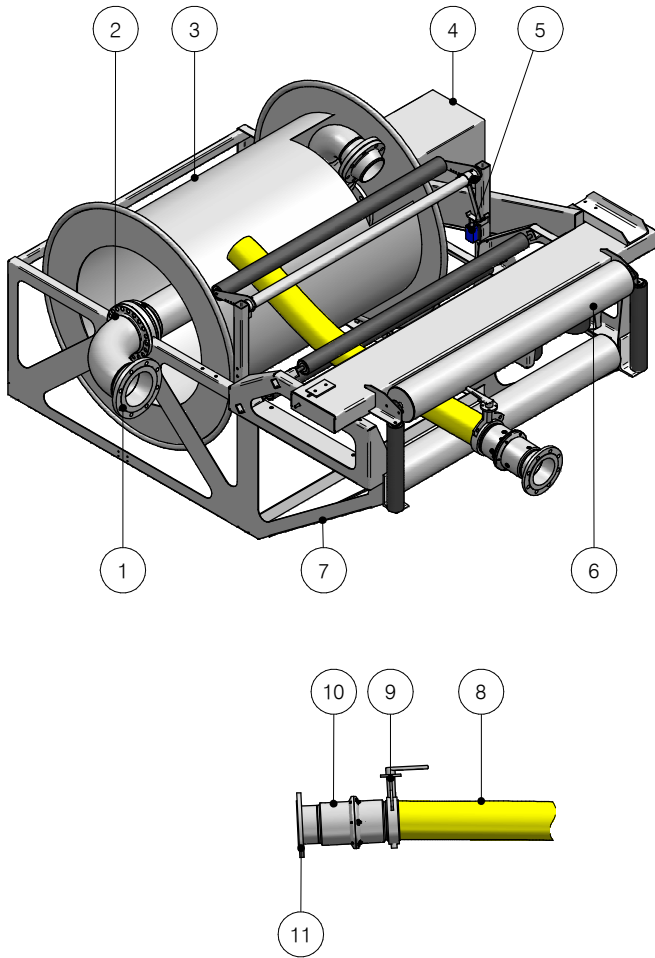

ITEM	SPECIFICATION
dimensions	DN100 (4"), DN150 (6"), DN200 (8")
material	stainless steel, steel (coated/galvanised)
connection	flanged ANSI/DIN
swivel joint	30-2000 (standard)
seals	PTFE, Viton, EPDM
hose	PP composite

PROCESS DATA	VALUES
pressure	up to 10 bar
temperature	-30°C / +80°C

No.	NAME
1	connection
2	swivel joint
3	reel
4	electric drive
5	hose double wind detection (optional)
6	hose guide (optional)
7	support frame
8	hose
9	shut-off valve (optional)
10	break away coupling (optional)
11	coupling / flange (optional)
12	earthing lug

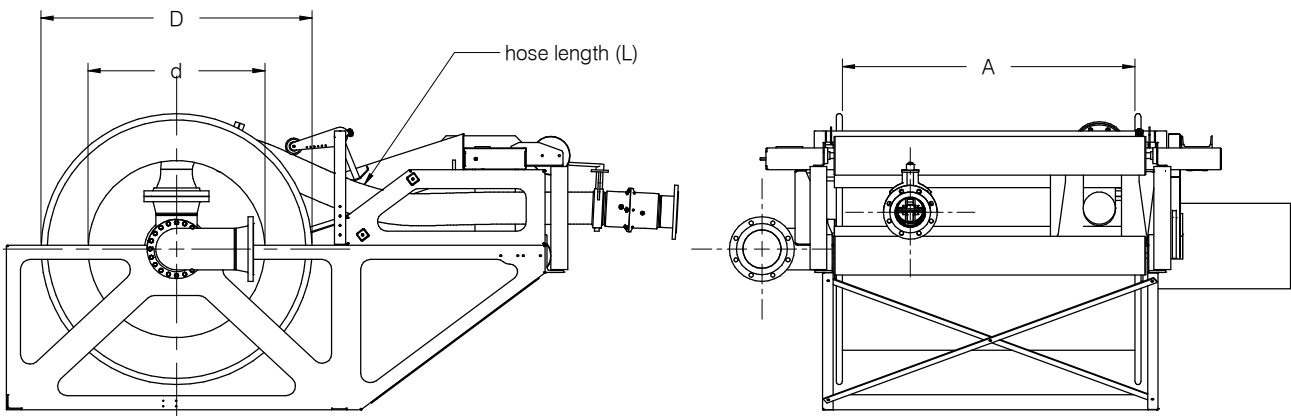

subject to technical modifications