

ITEM	SPECIFICATIE
afmetingen	DN50 (2"), DN80 (3"), DN100 (4"), DN150 (6")
materiaal	rvs, staal, aluminium
aansluiting	flenzen ANSI/DIN
swivel joint	30-2000 (standaard)
seals	PTFE, Viton, EPDM
balancing	veercilinder, contragewicht

PROCESGEGEVENS	WAARDEN
druk	tot 50 bar
temperatuur	-50°C / +200°C

NR.	OPTIES
1	aardkabel
2	afsluiter
3	deflector

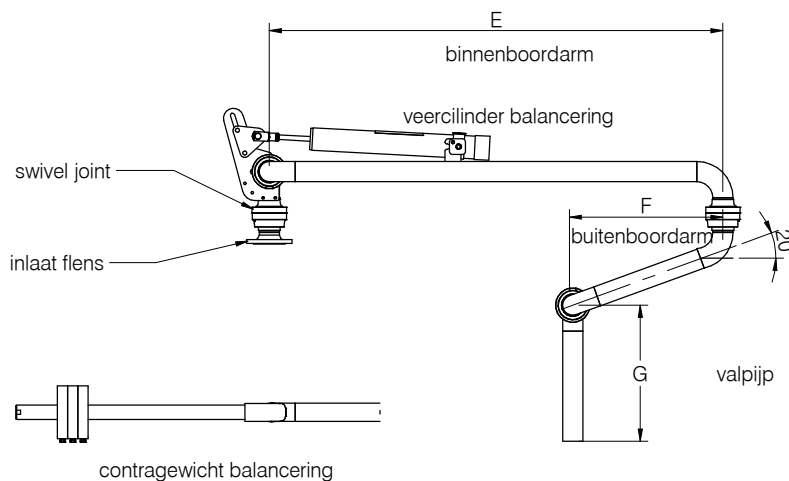
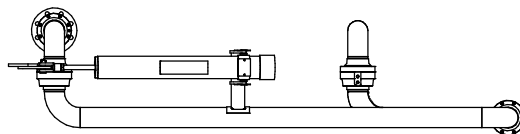

technische modificaties voorbehouden