

hose reel

type TH truck

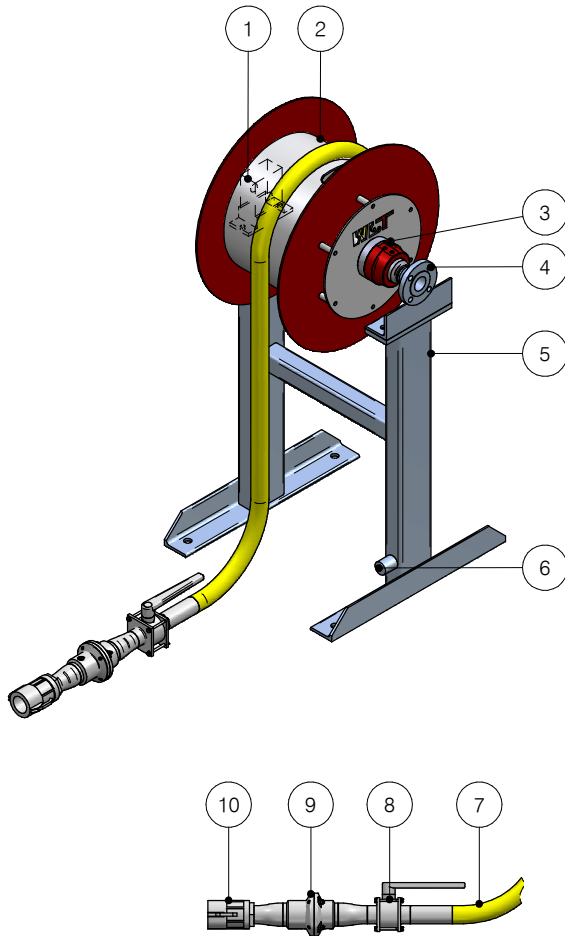

ITEM	SPECIFICATION
dimensions	DN25 (1"), DN50 (2"), DN80 (3")
material	stainless steel, steel (coated/galvanised)
connection	flanged ANSI/DIN
swivel joint	30-2000 (standard)
seals	PTFE, Viton, EPDM
hose	PP composite

PROCESS DATA	VALUES
pressure	up to 10 bar
temperature	-30°C / +80°C

No.	NAME
1	bearing
2	reel (spring rewind)
3	swivel joint
4	inlet
5	support frame
6	earthing lug
7	hose
8	shut-off valve (optional)
9	break away coupling (optional)
10	coupling / flange (optional)

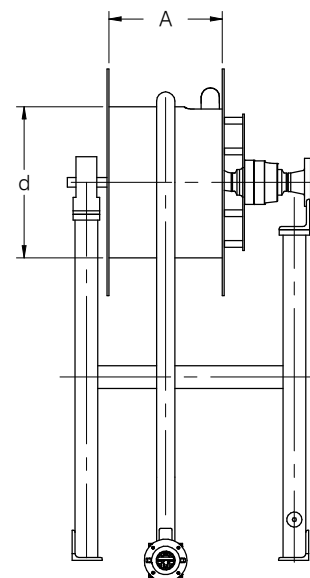
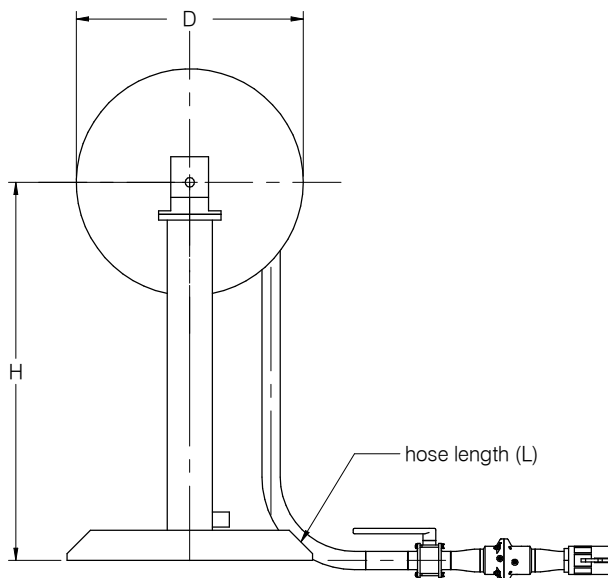

subject to technical modifications