

top loading arm

type TK

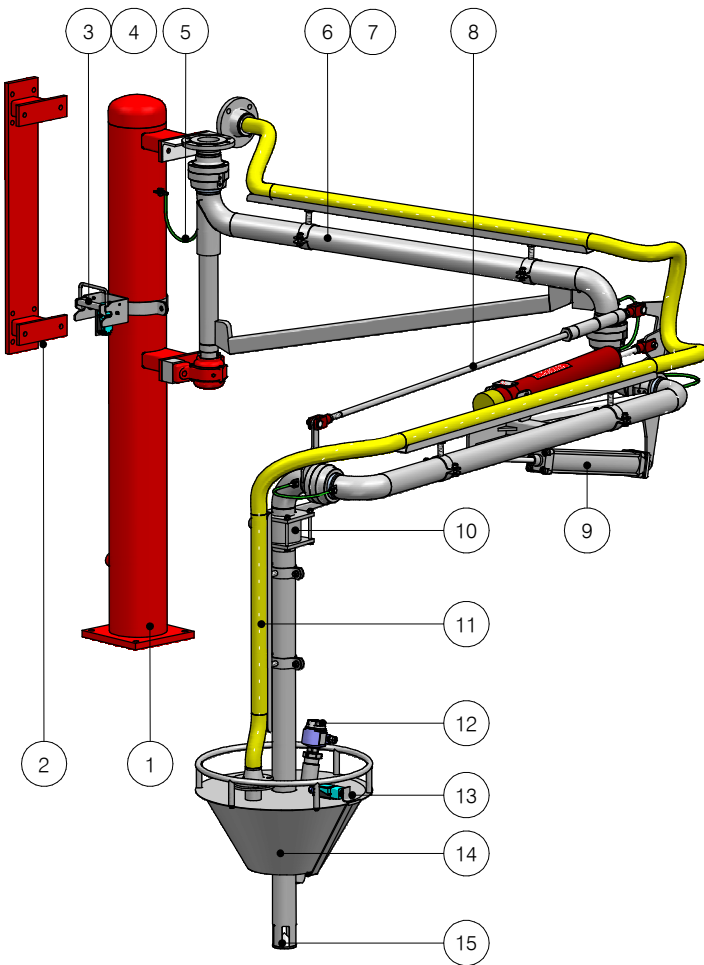

ITEM	SPECIFICATION
dimensions	DN50 (2"), DN80 (3"), DN100 (4"), DN150 (6")
material	stainless steel, steel, PTFE lined
connection	flanged ANSI/DIN
swivel joint	30-2000 (standard), 30-3620 (PTFE lined)
seals	PTFE, Viton, EPDM
balancing	spring cylinder, counterweight

PROCESS DATA	VALUES
pressure	up to 50 bar
temperature	-50°C / +200°C

No.	OPTIONS
1	stand post
2	wall bracket
3	locking device
4	parking detection
5	earthing cable
6	steam tracing, steam jacketing, electrical tracing
7	insulation
8	parallel linkage
9	pneumatical operation/press down
10	shut-off valve
11	vapour return hose
12	high level detection
13	manhole detection
14	vapour cone
15	deflector

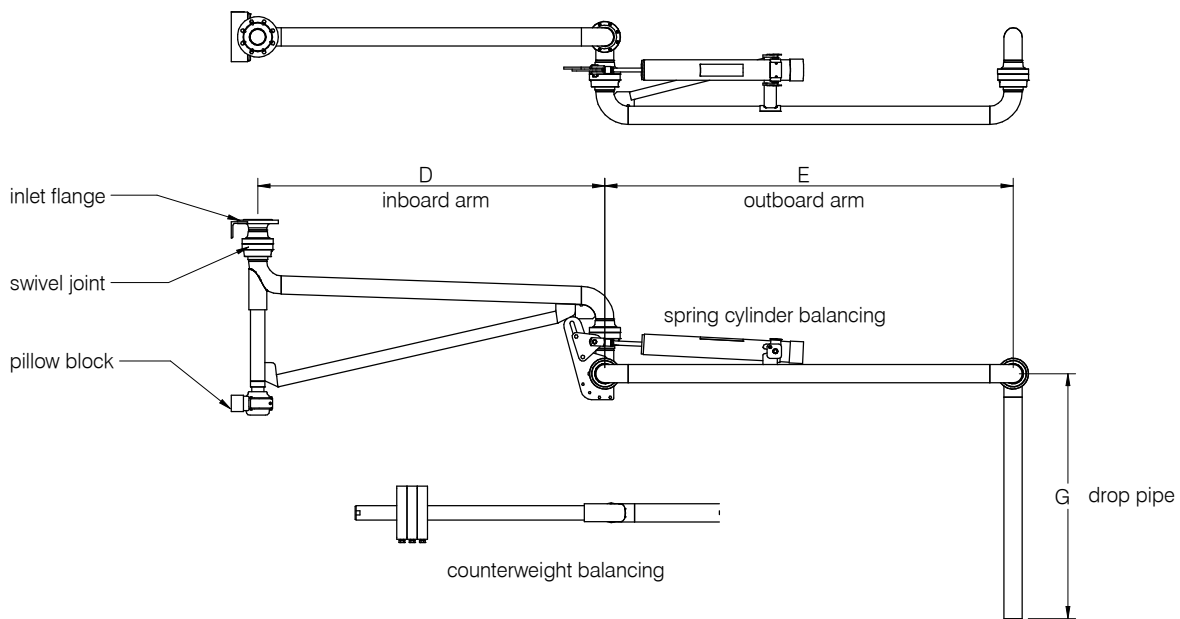

subject to technical modifications